

# 6254 General Industrial Footswitch Range

- Powder coated body/base die cast aluminium, its toughness and modest cost make it ideal for OEM applications
- Optional powder coated mild steel guard
- Pneumatic version available, please refer to Airswitching section for details
- Customer colours and logos available on request
- Ideal for remote switching in harsh environmental conditions where durability is required

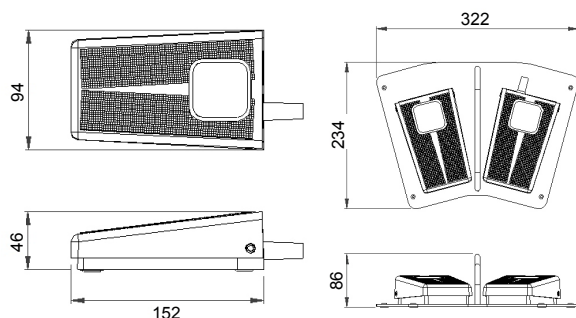

## Reference dimensions



## General specifications

<b>Standards/approvals</b>	footswitch: low voltage directive 2006/95/EC, EN 60950 microswitch: EN 61058-1, EN 61058	<b>Operating temperature range</b>	-5° C to + 40° C
<b>Degree of protection</b>	EN 60529 IPX2, IPX7 (IPX8 upon request)	<b>Body material</b>	Die cast aluminium
<b>Connection method</b>	Stripped cable cores or connector of your choice	<b>Weight</b>	See table below
<b>Electrical rating</b>	See table below	<b>Additional information</b>	Cordset variations of each standard option are available (6254-DO and DA versions can be build with cordset)
<b>Contact configuration</b>	See table below		

## 6254 - Range options and specifications

	Stock models					
Model No	6254-CT	6254-NT	6254-CC	6254-DO	6254-DA	6254-WO
Weight approx.	0.475 Kg	0.475 Kg	0.475 Kg	0.475 Kg	0.525 KG	0.525 Kg
Optional black guard			18 SWG mild steel, power coated			
No. of poles	SPCO	SPCO	SPCO	DPCO	DPCO staggered	SPST N/O
Cable	Terminal block	Push on terminal	3-core + earth	Terminal block	Terminal block	3-core + earth
Cable length standard	n/a	n/a	2 m	n/a	n/a	2 m
Cable O/D (mm)	n/a	n/a	7.5 (nom.)	n/a	n/a	6.8 (nom.)
Current rating @ 250V AC	6 (3)A	25A	6 (3)A	6 (3)A	6 (3)A	6 (1.5)A
Internal switch module	IPX2	IPX2	IPX2	IPX2	IPX2	IPX7

## Accessories

Part Number	Description
6202-0001	Single Black RAL 9005 guard
6202-0002	Single Grey RAL 7035 guard



With 6202 Guard